

FLK Xenon strobe beacon

- Ø 60 mm xenon strobe beacon
- Good signalling effect
- Sealed electronics
- For horizontal and vertical mounting
- 1 J strobe energy
- High degree of protection IP 65
- For general applications
- Good price/performance ratio



TECHNICAL DATA

Housing	Ø 60 mm, ABS black (RAL 9005)
Lens	Polycarbonate, ribbed inside orange, red or yellow
Type of mounting	horizontal or vertical
Cable entry	Back: Grommet 6-9 mm
Connection technology	Terminal 2,5 mm ²
Leakage current	0,003 A (PLC-suitable)
Beacon type	Xenon strobe beacon
Light source	Xenon tube
Luminous intensity	1 J Strobe energy
Strobe/flash frequency	1,4 Hz
Duty cycle	100 %
Service life	Light source: 10 million flashes
Operating temperature	-30°C/+60°C
Degree of protection	IP65
Weight	75 g

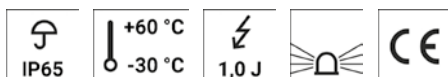
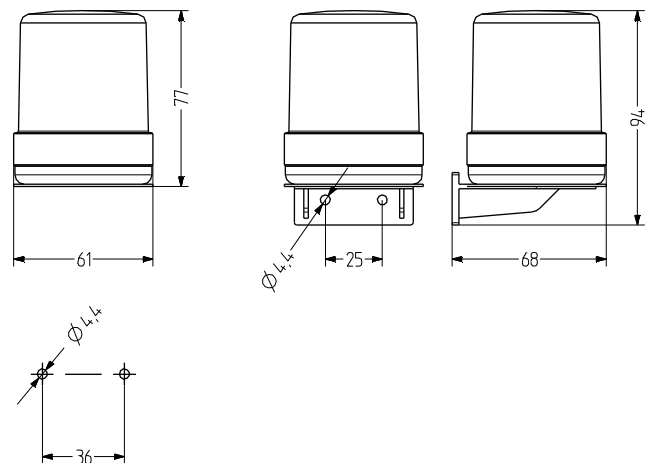

FLK

ORDER DATA - LENS

Lens colour	Nominal voltage	Voltage range (V)	Nominal current (A)	Order number
orange	12-24 V AC/DC	+/- 10 %	0,120	840 001 405
	230-240 V AC	+/- 10 %	0,024	840 001 313
red	12-24 V AC/DC	+/- 10 %	0,120	840 002 405
	230-240 V AC	+/- 10 %	0,024	840 002 313
yellow	12-24 V AC/DC	+/- 10 %	0,120	840 007 405
	230-240 V AC	+/- 10 %	0,024	840 007 313



BHF



BVF

ORDER DATA - BASE

Type	Type of accessory	Weight	Order number
BHF	Base for horizontal mounting	20 g	840 501 900
BVF	Base for vertical mounting	35 g	840 502 900



Strobe