

MBS Flashing beacon

- Ø 90 mm flashing beacon
- Distinct fresnel lens pattern for a good signalling effect
- Modular design – easy to mount/service
- 4 types of mounting
- 20 W halogen bulb included
- High degree of protection IP 65
- For industrial and general applications
- Captive safety screw for lens

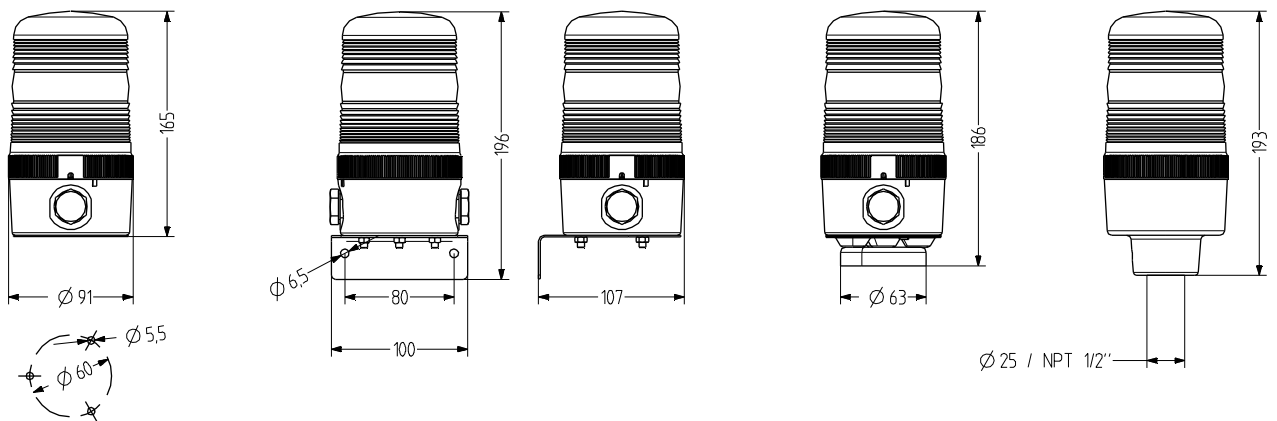

TECHNICAL DATA

Housing	Ø 90 mm, Polycarbonate black
Lens	Polycarbonate, ribbed (Fresnel) orange, red, clear, blue, green or yellow
Type of mounting	horizontal, vertical, Tube mounting, Magnetic mounting or upside down
Cable entry	side: 2× M20 with blind plugs (optional cable gland 5-12 mm), back: Grommet 5-7 mm
Connection technology	Terminal 2,5 mm ²
Leakage current	0,003 A (PLC-suitable)

Beacon type	Flashing beacon
Light source	Halogen bulb
Luminous intensity	20 W
Strobe/flash frequency	1 Hz
Duty cycle	100 %
Service life	Light source: 1.500 - 5.000 h
Operating temperature	-25°C/+60°C
Degree of protection	IP65 & UL Type 4/4x/13
Weight	270 g



MBS

ORDER DATA

Lens colour	Nominal voltage	Voltage range [V]	Nominal current [A]	Type of mounting		
				horizontal	Tube Ø 25 mm	Tube NPT 1/2"
orange	12 V AC/DC	+/- 10 %	1,700	837 101 404	837 301 404	837 311 404
	24 V AC/DC	+/- 10 %	0,830	837 101 405	837 301 405	837 311 405
	110-120 V AC	+/- 10 %	0,170	837 101 310	837 301 310	837 311 310
	230-240 V AC	+/- 10 %	0,085	837 101 313	837 301 313	837 311 313
red	12 V AC/DC	+/- 10 %	1,700	837 102 404	837 302 404	837 312 404
	24 V AC/DC	+/- 10 %	0,830	837 102 405	837 302 405	837 312 405
	110-120 V AC	+/- 10 %	0,170	837 102 310	837 302 310	837 312 310
	230-240 V AC	+/- 10 %	0,085	837 102 313	837 302 313	837 312 313
clear	12 V AC/DC	+/- 10 %	1,700	837 104 404	837 304 404	837 314 404
	24 V AC/DC	+/- 10 %	0,830	837 104 405	837 304 405	837 314 405
	110-120 V AC	+/- 10 %	0,170	837 104 310	837 304 310	837 314 310
	230-240 V AC	+/- 10 %	0,085	837 104 313	837 304 313	837 314 313
blue	12 V AC/DC	+/- 10 %	1,700	837 105 404	837 305 404	837 315 404
	24 V AC/DC	+/- 10 %	0,830	837 105 405	837 305 405	837 315 405
	110-120 V AC	+/- 10 %	0,170	837 105 310	837 305 310	837 315 310
	230-240 V AC	+/- 10 %	0,085	837 105 313	837 305 313	837 315 313
green	12 V AC/DC	+/- 10 %	1,700	837 106 404	837 306 404	837 316 404
	24 V AC/DC	+/- 10 %	0,830	837 106 405	837 306 405	837 316 405
	110-120 V AC	+/- 10 %	0,170	837 106 310	837 306 310	837 316 310
	230-240 V AC	+/- 10 %	0,085	837 106 313	837 306 313	837 316 313
yellow	12 V AC/DC	+/- 10 %	1,700	837 107 404	837 307 404	837 317 404
	24 V AC/DC	+/- 10 %	0,830	837 107 405	837 307 405	837 317 405
	110-120 V AC	+/- 10 %	0,170	837 107 310	837 307 310	837 317 310
	230-240 V AC	+/- 10 %	0,085	837 107 313	837 307 313	837 317 313



Flashing



WMS



MMR



MSR



MGS



AKV



MBK



MQS

ACCESSORIES

Type	Type of accessory	Tube length	Weight	Order number
WMS	Metal bracket for wall mounting		160 g	817 200 900
MMR	Tube mounting Aluminium with plastic foot	50 mm		698 806 007
		100 mm		698 806 008
		250 mm		698 806 009
		400 mm		698 806 010
MSR	Tube mounting Stainless steel with die-cast zinc foot, black (powder-coated)	50 mm		698 806 021
		100 mm		698 806 022
		250 mm		698 806 023
		400 mm		698 806 024
MGS	Magnetic fixing		340 g	817 203 900
AKV	Cable gland M20x1,5			698 800 026
MBK	Earthing kit for UL-compliant installation			819 201 900
MQS	Mounting plate for UL-compliant installation			817 202 900

REPLACEMENT PARTS

Type	Type of accessory	Nominal voltage	Output	Order number
HL21	Halogen bulb	12 V	20,000 W	890 020 904
HL22	Halogen bulb	24 V	20,000 W	890 020 905
HL25	Halogen bulb	110-120 V	20,000 W	890 020 910
HL26	Halogen bulb	230-240 V	20,000 W	890 020 913