

MFM Xenon strobe beacon

- Ø 120 mm xenon strobe beacon
- Very good signalling effect
- Modular design – easy to mount/service
- 4 types of mounting
- 15 J strobe energy
- High degree of protection IP 65
- For industrial and general applications
- Captive safety screw for lens

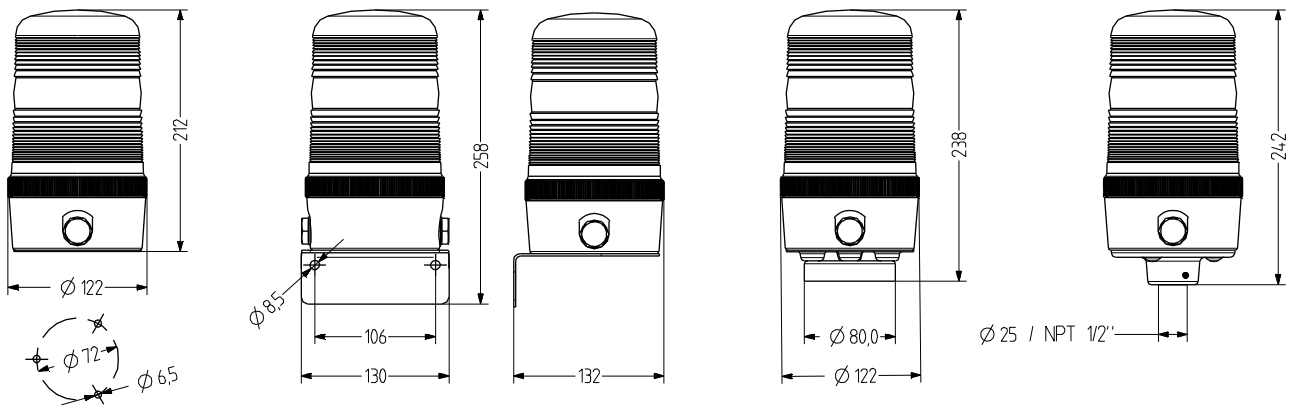

TECHNICAL DATA

Housing	Ø 120 mm, Polycarbonate black
Lens	Polycarbonate, ribbed (Fresnel) orange, red, clear, blue, green or yellow
Type of mounting	horizontal, vertical, Tube mounting, Magnetic mounting or upside down
Cable entry	side: 2× M20 with blind plugs (optional cable gland 5-12 mm), back: Grommet 5-7 mm
Connection technology	Terminal 2,5 mm ²
Leakage current	0,003 A (PLC-suitable)

Beacon type	Xenon strobe beacon
Light source	Xenon tube
Luminous intensity	15 J Strobe energy
Strobe/flash frequency	1 Hz
Duty cycle	100 %
Service life	Light source: 1.500 - 5.000 h
Operating temperature	-25°C/+60°C
Degree of protection	IP65 & UL Type 4/4x/13
Weight	520 g



MFM

ORDER DATA

Lens colour	Nominal voltage	Voltage range [V]	Nominal current [A]	Type of mounting		
				horizontal	Tube Ø 25 mm	Tube NPT 1/2"
orange	12-24 V AC/DC	+/- 10 %	1,300	848 101 405	848 301 405	848 311 405
	110-120 V AC	+/- 10 %	0,320	848 101 310	848 301 310	848 311 310
	230-240 V AC	+/- 10 %	0,150	848 101 313	848 301 313	848 311 313
red	12-24 V AC/DC	+/- 10 %	1,300	848 102 405	848 302 405	848 312 405
	110-120 V AC	+/- 10 %	0,320	848 102 310	848 302 310	848 312 310
	230-240 V AC	+/- 10 %	0,150	848 102 313	848 302 313	848 312 313
clear	12-24 V AC/DC	+/- 10 %	1,300	848 104 405	848 304 405	848 314 405
	110-120 V AC	+/- 10 %	0,320	848 104 310	848 304 310	848 314 310
	230-240 V AC	+/- 10 %	0,150	848 104 313	848 304 313	848 314 313
blue	12-24 V AC/DC	+/- 10 %	1,300	848 105 405	848 305 405	848 315 405
	110-120 V AC	+/- 10 %	0,320	848 105 310	848 305 310	848 315 310
	230-240 V AC	+/- 10 %	0,150	848 105 313	848 305 313	848 315 313
green	12-24 V AC/DC	+/- 10 %	1,300	848 106 405	848 306 405	848 316 405
	110-120 V AC	+/- 10 %	0,320	848 106 310	848 306 310	848 316 310
	230-240 V AC	+/- 10 %	0,150	848 106 313	848 306 313	848 316 313
yellow	12-24 V AC/DC	+/- 10 %	1,300	848 107 405	848 307 405	848 317 405
	110-120 V AC	+/- 10 %	0,320	848 107 310	848 307 310	848 317 310
	230-240 V AC	+/- 10 %	0,150	848 107 313	848 307 313	848 317 313



Strobe



WMM



MMR



MSR



MGM



AKV



MBK



MQM

ACCESSORIES

Type	Type of accessory	Tube length	Weight	Order number
WMM	Metal bracket for wall mounting		340 g	818 200 900
MMR	Tube mounting Aluminium with plastic foot	50 mm		698 806 007
		100 mm		698 806 008
		250 mm		698 806 009
		400 mm		698 806 010
MSR	Tube mounting Stainless steel with die-cast zinc foot, black (powder-coated)	50 mm		698 806 021
		100 mm		698 806 022
		250 mm		698 806 023
		400 mm		698 806 024
MGM	Magnetic fixing		600 g	818 203 900
AKV	Cable gland M20x1,5			698 800 026
MBK	Earthing kit for UL-compliant installation			819 201 900
MQM	Mounting plate for UL-compliant installation			818 202 900



XT15

REPLACEMENT PARTS

Type	Type of accessory	Order number
XT15	Xenon flashtube	890 115 900