



# Auer Signal

## Explosion-proof telephone connecting relay mTCR

### mTCR



### Order data

Designation	Type	Article no.
Telephone connecting relay	mTCR	410 100 100

### Description

The telephone connecting relay type mTCR is used as a fixed device in areas that may be at risk due to explosive gas or dust atmospheres and which require devices of device groups II and III of the categories 2G and 2D.

The designated position of normal use is not mandatory

The telephone connecting relay type mTCR is implemented in the following ignition protection classes:

Ex e ib mb IIC T4 Gb  
Ex tb IIIC T1 35°C Db  
IP66

Temperature range  
-40°C ≤ Ta ≤ +70°C

The telephone connecting relay type mTCR is intended for connection to analogue telephone networks. It can be simply installed parallel to a telephone.

The telephone connecting relay serves for call signalling through

providing potential-free switching contacts for the connection of signalling devices. This means for example that up to two external devices (e.g. a horn and a flash light) can be switched on via call signal. The call break bypass can be individually adjusted for one of the connected devices.

The installation regulations in accordance with IEC/EN 60079-14 as well as the respective national installation regulations must always be taken into consideration.

### Device structure

The telephone connecting relay type mTCR has an unpainted housing made of electrostatically conductive compressed material.

The housing consists of a box-shaped lower part for receiving the electronics module. The electronics module is firmly cast into the lower part of the housing and cannot be exchanged.

The cover is pressed onto the lower part of the housing using four screws, with a circumferential seal positioned in between. This forms the non-intrinsically-safe connection compartment.

### Intrinsically safe DIP switches

An intrinsically safe 4-pole sliding switch extends out from the casting within the device (see device overview) for pre-setting the desired mode of operation.

## Dimensions

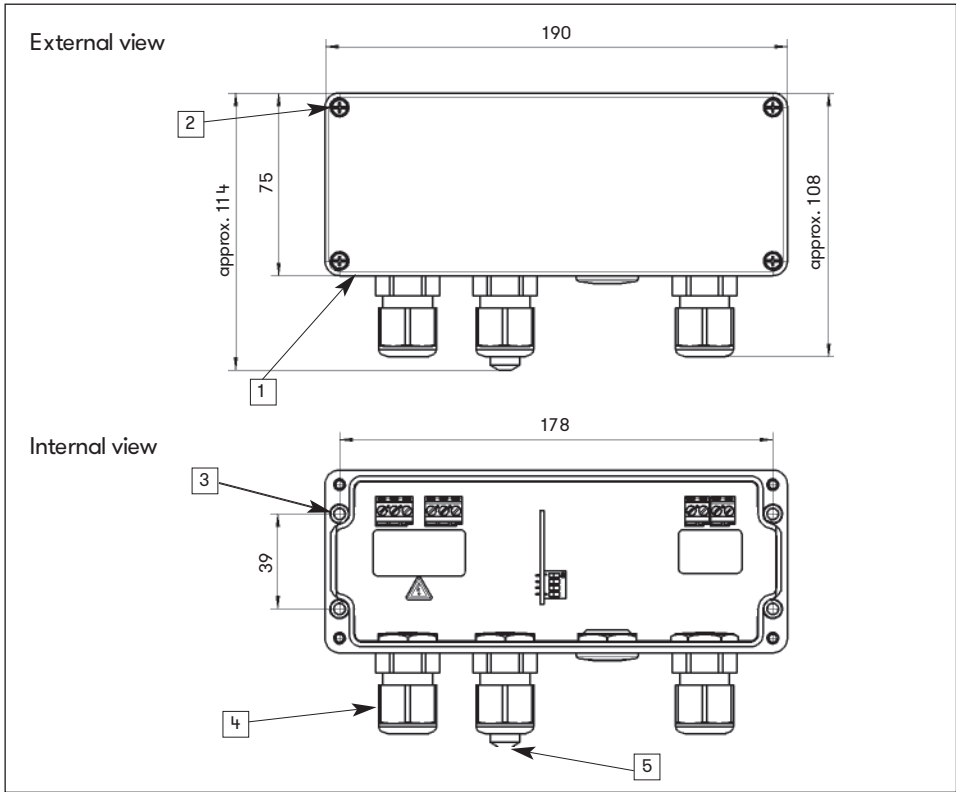

## Assembly and installation

Loosen the cover screws (2) and remove the cover (1) (see device overview). Insert the lower part into the opening (3) using four 4 mm screws with a head diameter of 6 mm to 7 mm and fasten to the wall or ceiling or onto a plate. If the head diameter of the screws is too small, suitable washers of 6 mm to 7 mm in diameter are to be used in addition. Lead the connection lines through the screwed cable connectors (KLE) (4) and connect them to terminals in accordance with connection diagram.

For the pre-installed cable glands, only lines are to be used which have a sheathing diameter  $\varnothing$  of 5.5 mm to 13 mm, since otherwise the IP66 housing protection class is not ensured.

The tightening torque of these screwed cable connectors is 3.5 Nm. The tightening torque of the cover screws is 1.2 Nm.

### NOTE:

**Excessive tightening compromises the protection class.**

The following is to be considered when assembling the sealing plug:

1. Only the sealing plug belonging to the cable gland (5) may be used.
2. The head side of the sealing plug must be on the outside (5).
3. The sealing plug (5) is to be pushed into the cable gland as far as it will go.

### CE symbol

We hereby declare this product is in compliance with the Essential Health and Safety Requirements of ATEX Directive 2014/34/EU, EMC Directive 2014/30/EU, Low Voltage Directive 2014/35/EU and RoHS Directive 2011/65/EU. The appropriate standards, technical regulations and specifications you can take from the attached conformity declaration.

## Maintenance

The telephone connecting relay type mTAR contains no parts that need maintaining.

### Maintenance and servicing

The equipment contains no parts that need maintaining. The specifications of EN 60079-17 regarding the regular inspection of explosion protection are to be adhered to.

### Start-up

After it has been connected to the telephone network, the device is ready for electrical operation.

### Requirements

none

## Electrical parameters

1. Telephone network (not intrinsically safe)  
Terminals No. 7 and 8 in accordance with 9 and 10

$$U_n = AC\ 90\ V / f = 25\ Hz$$

$$U_{m\_AC} = AC\ 100\ V / f = 20 \dots 68\ Hz$$

$$U_{m\_DC} = DC\ 66\ V$$

$$U_m = 120\ V_{eff}$$

AC and DC voltage parts can be superimposed.  
Permissible conductor cross-sections are 0.2 to 4.0 mm<sup>2</sup> rigid or 0.2 to 2.5 mm<sup>2</sup> flexible.

Only 2 or 4-core lines may be used.

2. Potential-free relay contacts (not intrinsically safe)  
Terminals No. 1/3 or No. 4/6

$$U_{max} = AC\ 250\ V$$

$$I_{max} = 5\ A$$

$$P_{max} = 100\ VA$$

In this case only lines with a core cross-section of 1.5 mm<sup>2</sup> to 4 mm<sup>2</sup> may be used.

Or

$$U_{max} = DC\ 230\ V$$

$$I_{max} = 0.5\ A$$

$$P_{max} = 100\ W$$

In this case only lines with a core cross-section of 0.75 mm<sup>2</sup> to 4 mm<sup>2</sup> may be used.

Or

$$U_{max} = DC\ 50\ V$$

$$I_{max} = 1\ A$$

In this case only lines with a core cross-section of 0.75 mm<sup>2</sup> to 4 mm<sup>2</sup> may be used.

Or

$$U_{max} = DC\ 30\ V$$

$$I_{max} = 5\ A$$

$$P_{max} = 100\ W$$

In this case only lines with a core cross-section of 1.5 mm<sup>2</sup> to 4 mm<sup>2</sup> may be used.

The terminals no. 2 and 5 according to the connection diagram may not be used. Only 2 or 4-core lines may be used.

3. The telephone network is securely and galvanically isolated from the potential-free relay contacts.

4. The two potential-free relay contacts are securely and galvanically isolated from one another up to a voltage of 440 V<sub>eff</sub>.

The voltage may not exceed 250 V<sub>eff</sub> at an individual relay contact.

## Connection diagram

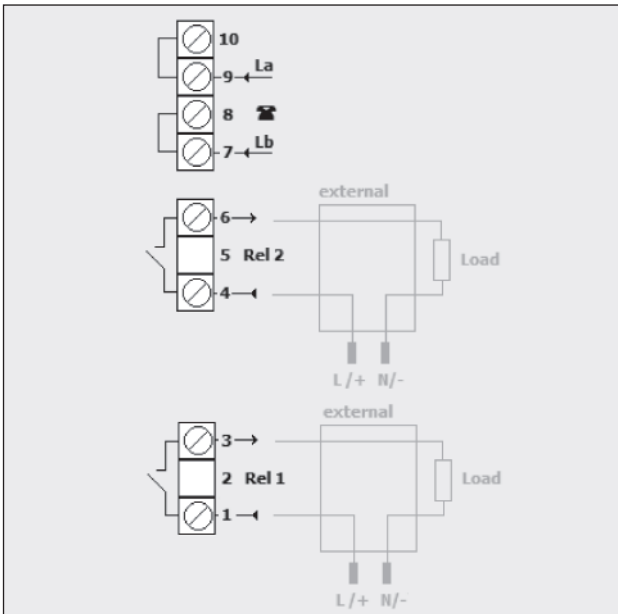

## Directives

The device complies with the requirements of the ATEX directive 2014/34/EU, the EMC-directive 2014/30/EU and the low voltage directive 2014/35/EU. The conformity with the above directives is confirmed by the CE sign.

## Applied standards

EN 60950  
ETSI TBR21  
ETSI ETS 30001 9-2-4  
IEC/EN 60079-0  
IEC/EN 60079-7  
IEC/EN 60079-11  
IEC/EN 60079-18  
IEC/EN 60079-31  
IEC/EN 60529  
EN 61000-4-3  
EN 61000-4-4  
EN 61000-4-5  
EN 61000-4-6  
EN 55022

## Technical data

### Housing

Material	Glass-fibre reinforced polyester
Height x width x depth	Approx. 75 mm x 190 mm x 75 mm
Weight	Approx. 1.1 kg
Normal operating position	Any

### Environmental conditions

Protection class	IP 66 in accordance with EN60529
Operating temperature	$-40^{\circ}\text{C} \leq T_a \leq 70^{\circ}\text{C}$
Transport and storage temperature	$-40^{\circ}\text{C}$ to $+70^{\circ}\text{C}$ in accordance with IEC 60721

### Further features

Power supply	Call AC voltage from the analogue telephone network. TNV-3 circuit. $U = AC\ 30\ \text{V} \dots 100\ \text{V}$																												
Call impedance	$M\ 8\ \text{k}\Omega$ (@ 30 V... 100 V/20... 68 Hz)																												
Modes of operation	Function of relay contact 1 (terminals 1 and 3) adjustable by means of sliding switches: Sliding switch 4 = OFF => contact follows the call signal Sliding switch 4 = ON => contact closes for approx. 1.5 seconds Function of relay contact 2 (terminals 4 and 6) adjustable by means of sliding switches. The contact always follows the call signal. After the call signal, i.e. in the call break that follows, the contact remains closed for the duration according to the following setting (call break bypass). 1 = ON => call break bypass approx. 1 second 2 = ON => call break bypass approx. 2 seconds 3 = ON => call break bypass approx. 3 seconds 1 to 3 = OFF => call break bypass approx. 9 seconds Combinations are possible: <table><thead><tr><th>1</th><th>2</th><th>3</th><th>Call break bypass approx.</th></tr></thead><tbody><tr><td>ON</td><td>OFF</td><td>OFF</td><td>1 s</td></tr><tr><td>OFF</td><td>ON</td><td>OFF</td><td>2 s</td></tr><tr><td>OFF</td><td>OFF</td><td>ON</td><td>3 s</td></tr><tr><td>OFF</td><td>ON</td><td>ON</td><td>5 s</td></tr><tr><td>ON</td><td>ON</td><td>ON</td><td>6 s</td></tr><tr><td>OFF</td><td>OFF</td><td>OFF</td><td>9 s</td></tr></tbody></table>	1	2	3	Call break bypass approx.	ON	OFF	OFF	1 s	OFF	ON	OFF	2 s	OFF	OFF	ON	3 s	OFF	ON	ON	5 s	ON	ON	ON	6 s	OFF	OFF	OFF	9 s
1	2	3	Call break bypass approx.																										
ON	OFF	OFF	1 s																										
OFF	ON	OFF	2 s																										
OFF	OFF	ON	3 s																										
OFF	ON	ON	5 s																										
ON	ON	ON	6 s																										
OFF	OFF	OFF	9 s																										

### Note:

The smooth functioning in the case of a "double call", i.e. two short call signals one behind the other, cannot be guaranteed given the abundance of double call signals worldwide. It is the operator's responsibility to test the function on his system in these cases.

### Marking

The type plate of the telephone connecting relay type mTCR is marked as follows:

Auer Signal GmbH  
Perfektastraße 102, A-1230 Vienna

Type mTCR  
BVS 15 ATEX E 028

CE 0408 (Ex)

II 2G Ex e Ib mb IIC T4 Gb  
II 2D Ex tb IIC T1 35°C Db  
 $-40^{\circ}\text{C} \leq T_a \leq +70^{\circ}\text{C}$

Manufacturing No.      xxxx  
Article no.                xxxx  
Inspection:                Month / year / inspector

$U_m = 120\ \text{V}$  IP66 IK08

WARNING – DO NOT OPEN WHEN LIVE

WARNING – WAIT 5 MINUTES AFTER SWITCHING OFF BEFORE OPENING

# EU-KONFORMITÄTSERKLÄRUNG

## EU DECLARATION OF CONFORMITY

### DECLARATION UE DE CONFORMITE

### DECLARACIÓN DE CONFORMIDAD UE



Hiermit erklären wir, dass das ATEX Produkt aufgrund seiner Konzipierung und Bauart sowie in der von uns in Verkehr gebrachten Ausführung den grundlegenden Sicherheits- und Gesundheitsanforderungen der genannten Richtlinie entspricht.

**Bei einer nicht mit uns abgestimmten Änderung des Produktes, verliert diese Konformitätserklärung Ihre Gültigkeit.**

We herewith declare that the ATEX product, based on its development and type as well on the specific design we have placed on the market, conforms to the Essential Health and Safety Requirements of the mentioned directive.

**This declaration shall become invalid if any modification we have not authorised is made to the product.**

Nous attestons, par le présent document, que le produit ATEX été conçu et fabriqué, quant au modèle mis en circulation par nos services, conformément aux exigences fondamentales de sécurité et de santé en vigueur de la ou des directives citées.

**En cas de modification du produit non convenue avec nos services, la présente déclaration perd sa validité.**

Por la presente declaramos que el producto ATEX satisface por su diseño tipo constructivo así como en la versión comercializada por nosotros los requisitos de seguridad y salud fundamentales y pertinentes de la directiva indicada.

**En caso de una modificación del producto no acordada con nosotros, la presente declaración pierde su validez.**

<b>Bezeichnung des Erzeugnisses</b>	<b>Telefonanschaltrelais</b>
Name of product	Telephone connecting relay
Titre Produit	Relais d'accès téléphonique
Nombre del producto	Relé de conexión de teléfono
<b>Typ / Type / Modèle / Tipo</b>	<b>mTCR</b>
<b>Richtlinie / Directive / Directiva</b>	<b>Normen / Standards / Normes / Normas</b>
2014/34/EU <b>Geräte und Schutzsysteme zur bestimmungsgemäßen Verwendung in explosionsgefährdeten Bereichen</b> Equipment and protective system intended for use in potentially explosive atmospheres Appareils et système de protection destinés à être utilisés en atmosphères explosibles Aparatos y sistemas de protección para uso en atmósferas potencialmente explosivas	<b>EN 60079-0:2012 + A11:2013</b> <b>EN 60079-7:2015</b> <b>EN 60079-11:2012</b> <b>EN 60079-18:2015</b> <b>EN 60079-31:2014</b>
<b>Die hier angewandten Normen sind mit dem Normenstand aus der EG-Baumusterprüfbescheinigung verglichen worden. Es gibt keine Änderungen des anerkannten Standes der Technik in Bezug auf dieses Gerät.</b> The edition of applied standards here has been compared with the edition in the EC-Type Examination Certificate. There are no changes in the state of the art apply to this equipment. Les normes appliquées ont été comparées avec les informations du certificat d'essai de type CE. Aucune modification de l'état de la technique reconnu n'est à noter concernant cet appareil. Las normas aplicadas fueron comparadas con las normas vigentes del certificado CE de examen de tipo. No hay cambios del estado reconocido de la técnica relativos a este aparato.	
<b>EG Baumusterprüfbescheinigung</b> EC-type-examination certificate Attestation examen CE Certificado de examen CE	<b>BVS 15 ATEX E 028</b>
<b>Benannte Stelle für die Bescheinigung</b> Notified body of the certificate Organisme notifié de l'attestation Organismo encargado del certificado	<b>DEKRA EXAM GmbH</b> Fachstelle für Sicherheit elektrischer Betriebsmittel – BVS Carl-Beyling-Haus Dinnendahlstraße 9 D-44809 Bochum
<b>Benannte Stelle für die Überwachung</b> Notified body of the inspection Organisme notifié de contrôle Organismo encargado del examen  <b>Kennummer</b> Inspection number / Numéro d'identification / Número de examen	<b>TÜV AUSTRIA SERVICES GMBH</b> Deutschstraße 10 A-1230 Wien  <b>0408</b>
<b>Hersteller / Anschrift</b> Manufacturer / Factory address Fabricant / fabricante	<b>Auer Signal GmbH</b> Perfektastr. 102 A-1230 Wien

**Geschäftsführer:**

Managing director / Direction / Gérant / Gerente:

**Mag. Christian Auer**

(Name, Vorname / name, prename / nom, prénom / apellido y nombre)

**Wien**

(Ort / place / lieu / población)

**15.05.2018**

(Datum / date / date / fecha)

(Unterschrift / signature / signature / Firma)

## Warnings and safety instructions

This device is an explosion-proof telephone connecting relay specially for operation in a hazardous industrial environment. The following warnings and safety instructions are to be considered:

1. The device serves for call signalling at analogue telephone connections through providing potential-free switching contacts for connecting signalling devices. It is not intended for use in safety-related applications.
2. The device is constructed in protection class II and may only be connected and operated at the prescribed voltage. A correct connection is to be ensured. The connection line is to be installed in such a way that there is no risk of stumbling.
3. The device may only be operated under the ambient conditions indicated [see chapter "description"]. Adverse ambient conditions, such as too high or too low an ambient temperature, are not permissible since these encourage the failure of electronic components.
4. It is to be ensured that the device, the connection cable etc. are not damaged. If damaged, operating the device is not permissible.
5. When operating the device, the legal and commercial regulations, the accident prevention regulations and the electrical codes are to be taken into consideration.
6. In the case of repairs, only original spare parts are permissible, which must be exchanged in a technically correct manner. Other replacement parts may lead to damage and to the warranty expiring.
7. The device must be de-energised for it to be opened.
8. After switching off, wait 5 minutes before opening.
9. When open, no dust may get into the device.
10. The cover seal necessary for the tightness of the housing as well as the collar at the lower part of the housing may not be damaged during assembly and disassembly.
11. When reconditioning the equipment for use in dust, the reconditioned parts should undergo another routine check test.
12. Changes to the product which serve for technical advancement may be made without being announced beforehand.
13. If using a 4 core installation cable (NYM-J 4x 1,5 mm<sup>2</sup>) and the 5 A load each of both relays at an environmental temperature of +70 °C a temperature of +74 °C will be achieved at the cable inlet. It has to be made sure, that a suitable installation cable will be chosen.
14. The manufacturer assumes no liability for the connection being correct!  
If the aforementioned points are not adhered to, the explosion protection of the device is no longer ensured and the device then puts the life of the operator in danger and can cause an explosive atmosphere to be ignited.
15. The connection and the installation of the device have to be carried out by an instructed specialist in accordance with the prescribed installation regulations and taking the indicated ignition protection class into consideration.

Subject to alterations or errors



# Auer Signal

## Auer Signal GmbH

Perfektastr. 102  
A-1230 Wien

Phone (0043) 1 813 82 20  
Telefax (0043) 1 815 99 51

<http://www.auersignal.com>  
e-mail: [office@auersignal.com](mailto:office@auersignal.com)