

## XB2 Xenon strobe beacon

- Ø 65 mm compact xenon strobe beacon
- Prewired, 400 mm connecting cord
- Degree of protection IP 65
- Good signalling effect
- 2 J strobe energy
- With mounting adapter, can be mounted from the front
- Suitable for simple standard applications
- Cost-effective

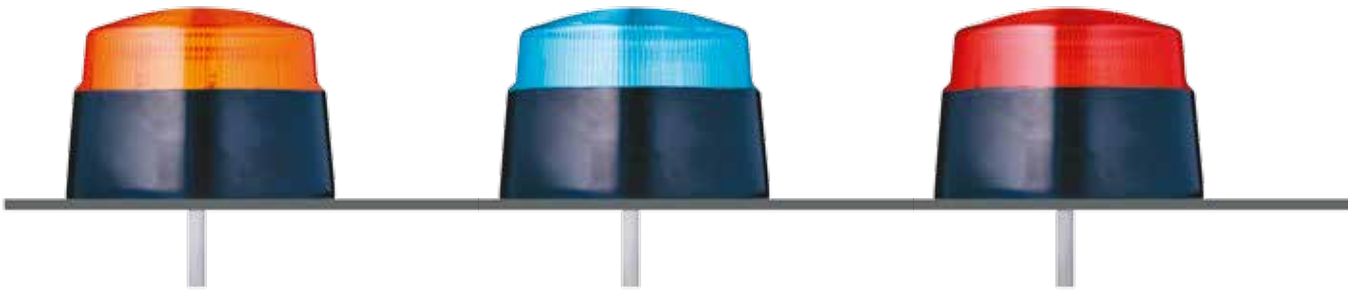

### TECHNICAL DATA

Housing	Ø 65 mm, ABS black (RAL 9005)
Lens	Polycarbonate, ribbed inside orange, red or blue
Type of mounting	horizontal
Cable entry	pre-wired (400 mm cable)
Beacon type	Xenon strobe beacon
Light source	Xenon tube
Luminous intensity	2 J Strobe energy
Strobe/flash frequency	1 Hz
Duty cycle	100 %
Service life	Light source: 500,000 flashes
Operating temperature	-20°C/+70°C
Degree of protection	IP65

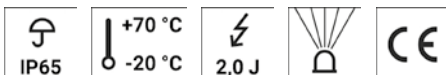
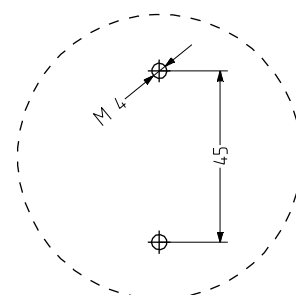
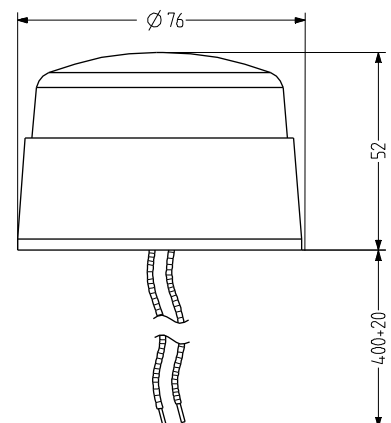

# XB2

## ORDER DATA

Lens colour	Nominal voltage	Voltage range (V)	Nominal current (A)	Order number
orange	12 V DC	+/- 10 %	0,200	D118 521 004
	24 V DC	+/- 10 %	0,100	D118 521 005
	24 V AC	+/- 10 %	0,220	D118 521 305
	230 V AC	+/- 10 %	0,025	D118 521 313
red	12 V DC	+/- 10 %	0,200	D118 522 004
	24 V DC	+/- 10 %	0,100	D118 522 005
	24 V AC	+/- 10 %	0,220	D118 522 305
	230 V AC	+/- 10 %	0,025	D118 522 313
blue	230 V AC	+/- 10 %	0,025	D118 525 313



Strobe