

BZG Xenon strobe beacon

- Ø 72 mm (lens) xenon strobe beacon
- Very good signalling effect
- Die-cast aluminium housing, epoxy powder-coated for use in harsh conditions
- 15 J strobe energy
- High degree of protection IP 66
- For industrial and general applications



TECHNICAL DATA

| | |
|------------------------|--|
| Housing | Ø 72 mm, Die-cast aluminium, epoxy powder-coated grey (RAL 7000) |
| Lens | Polycarbonate, ribbed inside orange, red or yellow |
| Type of mounting | horizontal |
| Cable entry | side: M20 with blind plug (optional cable gland 5-12 mm) |
| Connection technology | Screw/plug-in terminal 2,5 mm ² |
| Leakage current | 0,003 A (PLC-suitable) |
| Beacon type | Xenon strobe beacon |
| Light source | Xenon tube |
| Luminous intensity | 15 J Strobe energy |
| Strobe/flash frequency | 1 Hz |
| Duty cycle | 100 % |
| Service life | Light source: 5 million flashes |
| Operating temperature | -30°C/+50°C |
| Degree of protection | IP66 |
| Weight | 600 g |

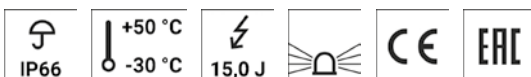
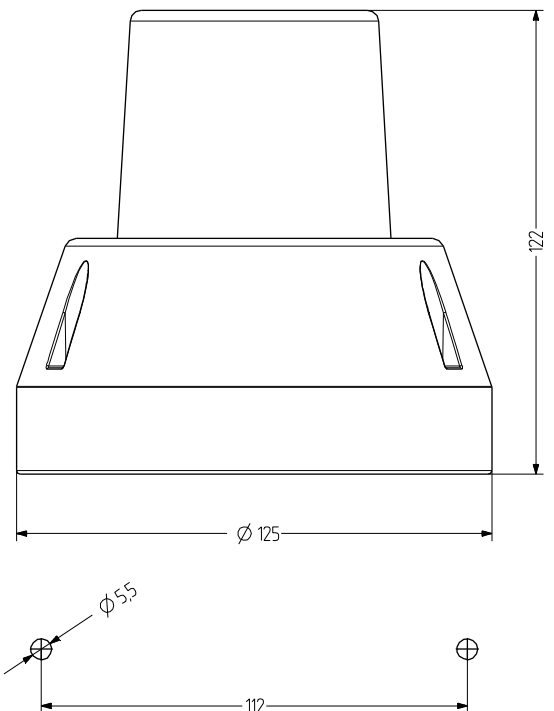

BZG

ORDER DATA

| Lens colour | Nominal voltage | Voltage range (V) | Nominal current (A) | Order number |
|-------------|-----------------|-------------------|---------------------|--------------|
| orange | 24 V DC | +/- 10 % | 0,700 | 741 041 005 |
| | 230-240 V AC | +/- 10 % | 0,230 | 741 031 313 |
| red | 24 V DC | +/- 10 % | 0,700 | 741 042 005 |
| | 230-240 V AC | +/- 10 % | 0,230 | 741 032 313 |
| yellow | 24 V DC | +/- 10 % | 0,700 | 741 047 005 |
| | 230-240 V AC | +/- 10 % | 0,230 | 741 037 313 |



Strobe