

## ESP Panel mount buzzer

- Ø 35 mm (mounting nut) panel-mount buzzer
- Max. 90 dB (A) sound pressure
- Wide voltage range
- Panel size Ø 28 mm/M28
- Pulsing tone
- Connection via tabs
- For industrial and general applications
- Sealed electronics, low current consumption



### TECHNICAL DATA

Housing	ABS grey or black
Type of mounting	any
Panel size	28 mm (M28)
Connection technology	Flat connector
Tone	Pulsing tone
Volume	90 dB
Tone frequency	2,400 Hz
Duty cycle	100 %
Operating temperature	-20 °C / +60 °C
Degree of protection	IP30
Weight	55 g

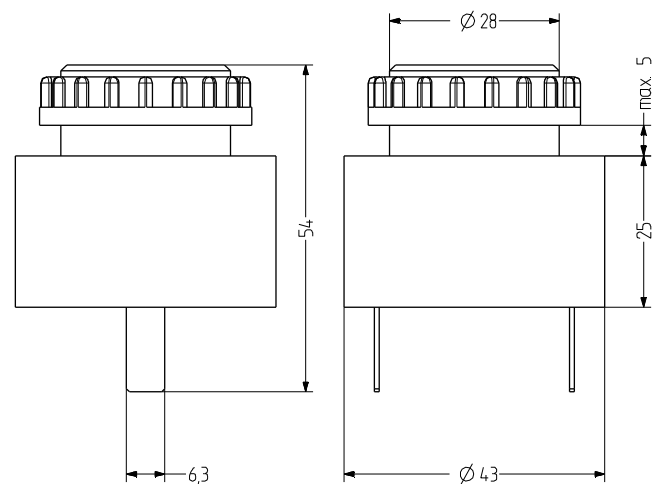

# ESP

## ORDER DATA

Nominal voltage	Voltage range (V)	Nominal current (A)	Mains frequency	Housing colour	
				grey	black
24 V AC/DC	4-40	0,020	50-60 Hz	811 000 405	811 100 405
48 V AC/DC	10-48	0,020	50-60 Hz	811 000 408	811 100 408
230-240 V AC	30-250	0,020	50-60 Hz	811 000 313	811 100 313