

## TH1 Telephone sound protection hoods

- Suitable for all types of telephone
- For better audibility of telephone conversations in noisy ambient conditions
- Inner lining of perforated sheet steel
- Excellent sound absorption >25 dB (A) in 1 m
- Various housing colours
- Available housing materials
- GFRP – glass-fibre-reinforced plastic
- PVC – plastic, UV and weather-resistant
- Hot-dip galvanised sheet steel, powder-coated
- Stainless steel
- Console available as an option



### TECHNICAL DATA

Sound absorption	bis 25 db (A) in 1 m
Insulating material	Rockwool RAF-SE
Housing	galvanised sheet steel, Stainless steel, glass-fibre-reinforced plastic (GFRP), Plastic (hard PVC, UV and weather-resistant) and Console (sheet steel, powder-coated) yellow (RAL 1023), orange (RAL 2000), red (RAL 3020) or Stainless steel
Weight	35 kg

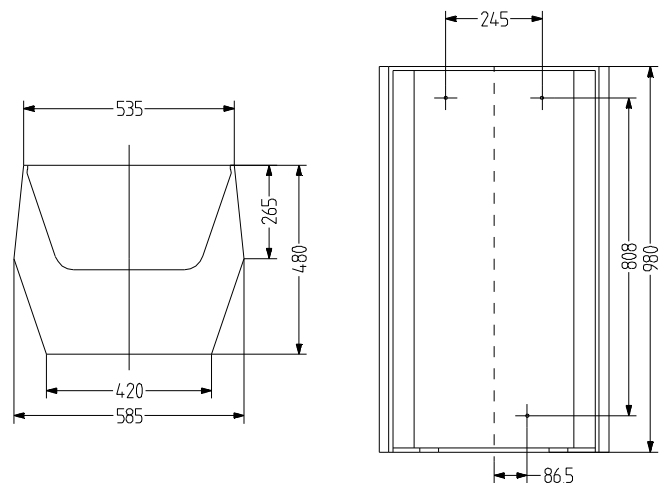

# TH1

## ORDER DATA

Type	Housing material	Housing colour	Order number
TH1	glass-fibre-reinforced plastic (GFRP)	orange	410 100 007
	Metal	yellow	410 100 006
TH1C	Console (sheet steel, powder-coated)	yellow	410 100 011

