

PXH Xenon strobe beacon

- Ø 75 mm xenon strobe beacon
- Prewired with 1 m PUR cable – ready to use
- High degree of protection IP 67 & IP 69
- 5 J strobe energy – good signalling effect
- Premounted stainless-steel fixing screws
- 3 types of mounting, for industrial and general applications



Sealed cable insulation/entry

TECHNICAL DATA

Housing	Ø 75 mm, 100 mm High lens , Polycarbonate black (RAL 9005)
Lens	Polycarbonate, ribbed inside orange, red
Type of mounting	any
Cable entry	pre-wired (1 m cable)
Leakage current	0,003 A (PLC-suitable)
Beacon type	Xenon strobe beacon
Light source	Xenon tube
Luminous intensity	5 J Strobe energy
Strobe/flash frequency	1,4 Hz
Duty cycle	100 %
Service life	Light source: 5 million flashes
Operating temperature	-30°C/+60°C
Degree of protection	IP67 & IP69
Impact resistance	IK08
Weight	220 g

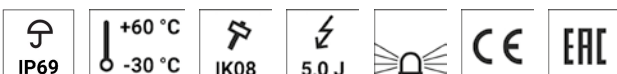
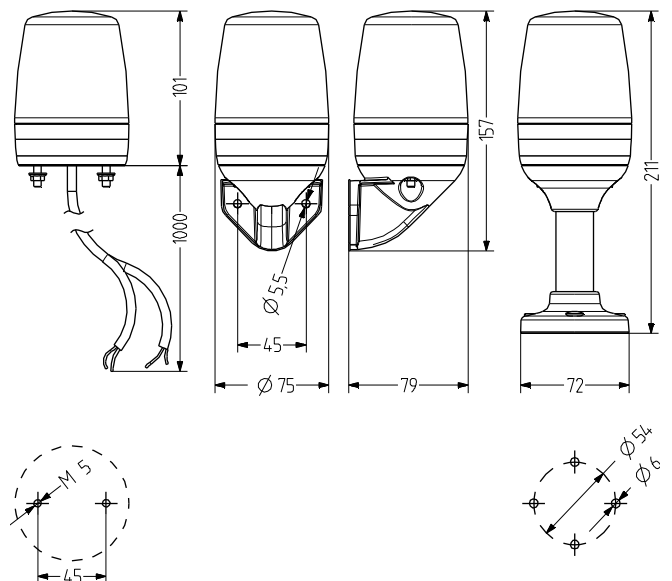

PXH

ORDER DATA

Lens colour	Nominal voltage	Voltage range (V)	Nominal current (A)	Order number
amber	10-100 V AC/DC	20-70 V AC	0,260	860 521 410
		10-100 V DC		
red	10-100 V AC/DC	180-264	0,055	860 521 313
		230-240 V AC		
red	10-100 V AC/DC	20-70 V AC	0,260	860 522 410
		10-100 V DC		
red	10-100 V AC/DC	180-264	0,055	860 522 313
		230-240 V AC		



Strobe



PMR



PVW



XWR

ACCESSORIES

Type	Type of accessory	Tube length	Weight	Order number
PMR	Tube base Aluminium tube with plastic foot	100 mm		860 702 900
		250 mm		860 703 900
PVW	Bracket for vertical mounting			860 600 900
XWR	Bracket for vertical mounting of TMR/UMR tube base		95 g	900 600 900