

wFT3 weather-proof analogue telephone

- For universal applications, resistant to high humidity, maritime climates, etc.
- High degree of protection IP 65
- Impact-resistant polycarbonate housing
- Housing colours yellow, grey and black
- Available with armoured or spiral cord as an option
- Models with or without display/keypad
- Receiver can be fixed with stabiliser bracket
- Can be used as a desk-mounted or wall-mounted telephone
- Receiver can be securely fixed with stabiliser bracket
- Comprehensive range of accessories

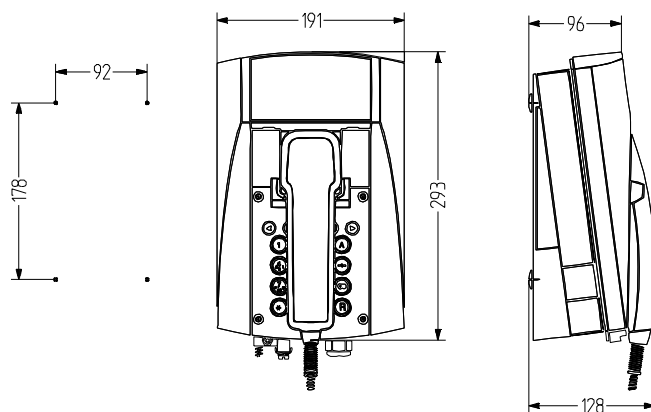

TECHNICAL DATA

Dialling method	DTMF as per ITU-T Q.23 Tone duration unlimited or 90 ms PD pulse/pause ratio 1.5:1 (60/40 ms) or 2:1 (66.7/33.3 ms)
Tone ringing volume	95 dB
Ringing frequency	programmable: 16–68 Hz
Incoming telephone line	TCP/La, TCP/Lb
Second bell	w1, w
Housing	Polycarbonate black, black/grey or black/yellow
Type of mounting	vertical wall mounting or Table mounting
Cable entry	1× M20 × 1.5 cable gland, 1× M20 × 1.5 blind plug, 2× M12 × 1.5 blind plugs
Connection technology	single wire or multiple wires up to 2.5 mm ²
Operating temperature	-25 °C / +55 °C

Operating temperature	-25°C to 55°C (display: 12:12 -10°C to +50 °C)
Degree of protection	IP65
Technology	analogue
Supply voltage	24 - 66 DC
Supply current	0,019 - 0,10 A
Ringing alternating current	30 - 90 V AC
Weight	2,295 kg
Display	2-line alphanumerical display with pictograms, visible area 78 × 26 mm
Mouthpiece	Electret microphone
Receiver	dynamic receiver with magnetic field generator
Stabiliser bracket	optional
Handset cord	Spiral cord

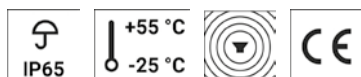

wFT3

ORDER DATA

Cord	Keypad	Display	Housing colour	Order number
Coiled cord	with keypad	without display	black/grey	410 310 300
			black/yellow	410 310 100
		with display	black/yellow	410 300 100
			black	410 300 000
Armoured cord	with keypad	without display	black/yellow	410 320 100



TCR



TH1

ACCESSORIES

Type	Type of accessory	Colour	Housing material	Weight	Order number
TH1	Telephone sound protection hood	yellow (RAL 1023)	Console (sheet steel, powder-coated)	17 kg	410 100 011
			Metal	35 kg	410 100 006
		orange (RAL 2000)	glass-fibre-reinforced plastic (GFRP)	40 kg	410 100 007
TCR	Weather-proof telephone switch relay			750 g	410 100 200
STB	Stabiliser bracket				410 400 900

