

## PXL Xenon strobe beacon

- Ø 75 mm compact xenon strobe beacon
- Prewired with 1 m PUR cable – ready to use
- High degree of protection IP 67 & IP 69
- 2 J strobe energy – good signalling effect
- Premounted stainless-steel fixing screws
- 3 types of mounting, for industrial and general applications



Sealed cable  
insulation/entry

### TECHNICAL DATA

Housing	Ø 75 mm, 55 mm High lens , Polycarbonate black (RAL 9005)
Lens	Polycarbonate, ribbed inside orange, red
Type of mounting	any
Cable entry	pre-wired (1 m cable)
Leakage current	0,003 A (PLC-suitable)
Beacon type	Xenon strobe beacon
Light source	Xenon tube
Luminous intensity	2 J Strobe energy
Strobe/flash frequency	1,4 Hz
Duty cycle	100 %
Service life	Light source: 5 million flashes
Operating temperature	-30°C/+60°C
Degree of protection	IP67 & IP69
Impact resistance	IK08
Weight	170 g

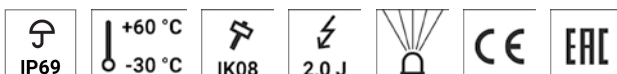
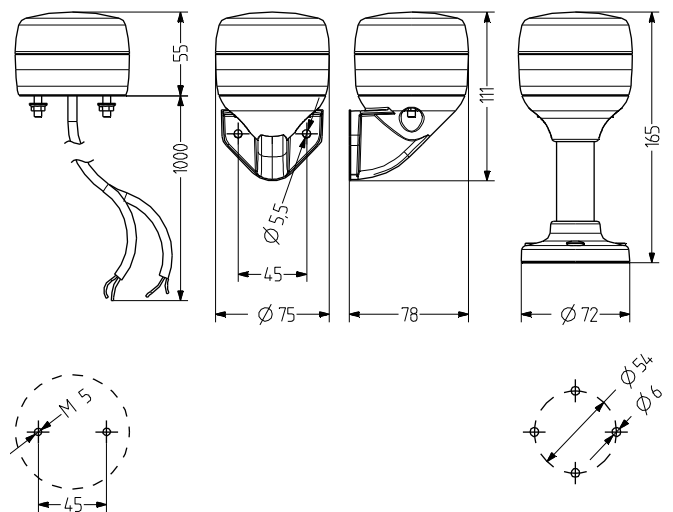

# PXL

## ORDER DATA

Lens colour	Nominal voltage	Voltage range (V)	Nominal current (A)	Order number
amber	230-240 V AC	170-264	0,045	861 521 313
	20-70 V AC	20-70 V AC	0,250	861 521 410
	10-100 V DC	10-100 V DC		
red	230-240 V AC	170-264	0,045	861 522 313
	20-70 V AC	20-70 V AC	0,250	861 522 410
	10-100 V DC	10-100 V DC		



Strobe



PMR



PVW



XWR

## ACCESSORIES

Type	Type of accessory	Tube length	Weight	Order number
PMR	Tube base Aluminium tube with plastic foot	100 mm		860 702 900
		250 mm		860 703 900
PVW	Bracket for vertical mounting			860 600 900
XWR	Bracket for vertical mounting of TMR/UMR tube base		95 g	900 600 900