

## VS2 weather-proof visual-audible telephone call signalling sounder

- Weather-proof visual-audible telephone call signalling sounder
- Several tones/intermittent tone frequencies can be selected
- Die-cast aluminium housing
- High degree of protection IP 66
- Mains power supply (230 V AC)
- For universal use in harsh ambient conditions
- Makes a telephone call more noticeable
- 5 lens colours can be selected



### TECHNICAL DATA

audible signal transmitter	Piezo disc
visual signal transmitter	Xenon flashtube with 3 J 230 V AC +/-10%
Call pause bypass	4 s
Tone ringing volume	95 dB
Ringing frequency	16 - 54 Hz
Input impedance	bei 25 Hz $Z \geq 8 \text{ k}\Omega$ bei 50 Hz $Z \geq 4 \text{ k}\Omega$
Pause duration	$\geq 30 \text{ min.}$
Housing	Die-cast aluminium black (RAL 9005)
Lens	Polycarbonate, orange, red, clear, blue or green
Type of mounting	Wall mounting
Cable entry	2xM20x1,5, 5-9mm
Connection technology	up to 1.5 mm <sup>2</sup> single or fine wire
Strobe/flash frequency	2-4 Hz
Tone	4 Tones, Two tones or Three tones can be selected with DIP switch
Duty cycle	$\leq 30 \text{ min.}$
Operating temperature	-20 °C / +60 °C
Degree of protection	IP66
Supply voltage	0 V DC - 48 V DC 48 V DC - 63 V DC
Ringing alternating current	24 V AC - 85 V AC 24 V AC - 80 V AC
Insulation class	I
Weight	935 g

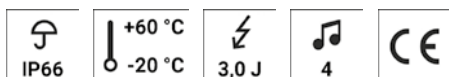
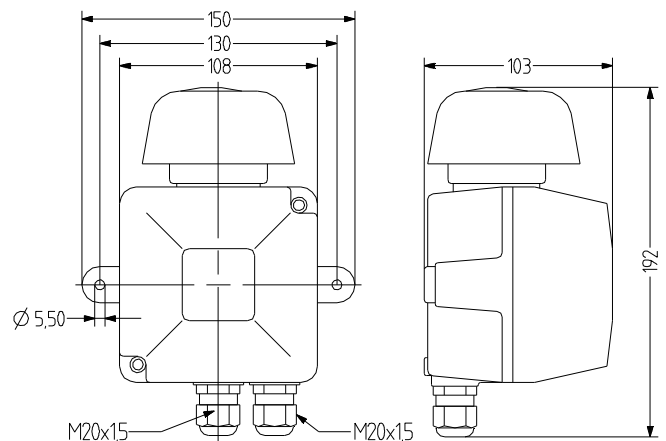

# VS2

## ORDER DATA

Lens colour	Order number
orange	410 201 005
red	410 202 005
clear	410 204 005
blue	410 205 005
green	410 206 005

